

FIBROMAT AT.1600
Antriebsausrichtung 10, 20, 30, 40

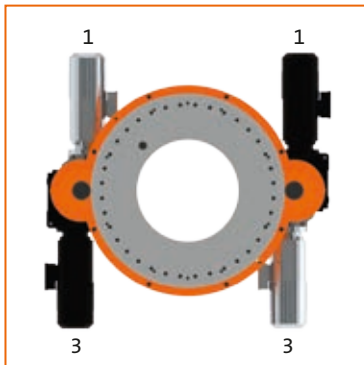

FIBROMAT AT.1600
Drive arrangement 11, 13, 31, 33

Dimensions of FIBROMAT® AT.1600

(Drive arrangement 180° with one drive; for other drive arrangements, diagrams or CAD data are available)

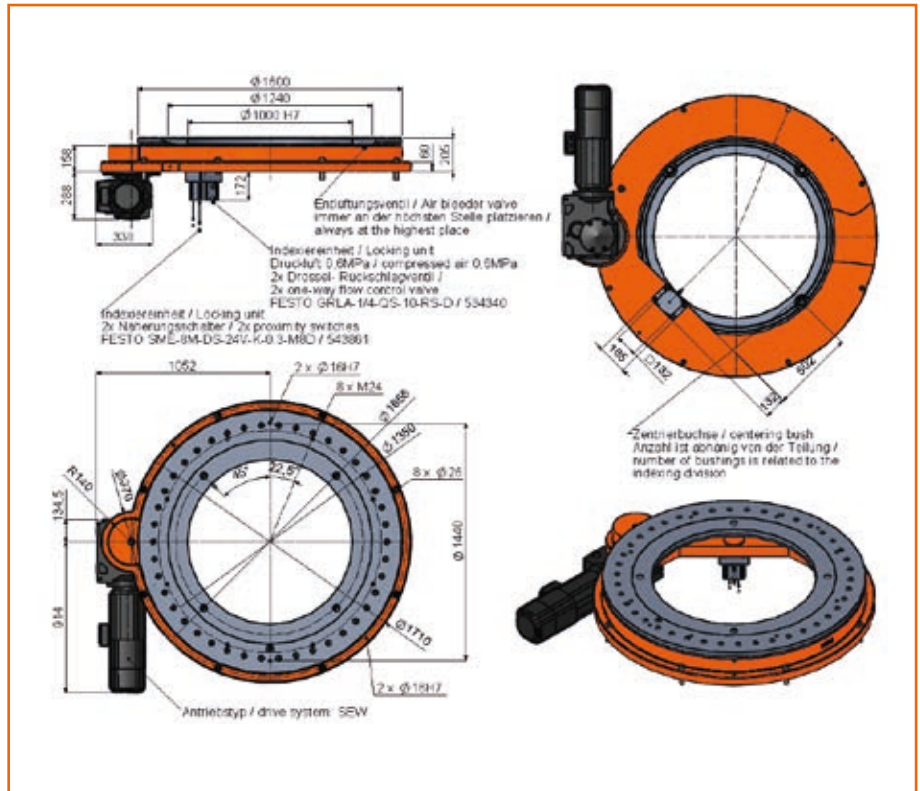

Technical data for FIBROMAT® AT.1600

Coding

AT.1600 . . .

Table top dimension	Ø 1,600 mm		
Drive motor	1 drive without motor 1 drive with motor 1 drive with motor 1 drive with motor 2 drives without motor 2 drives with motor 2 drives with motor 2 drives with motor	Gearbox prepared for motor according to customer SEW asynchronous servo gear motor KF87/R DRL 132MC4BE5/TF/AS7W/Z SIEMENS Motor 1FK7105-5AF71-1EH0 Special motor Gearboxes prepared for motors according to customer SEW asynchronous servo gear motor KF87/R DRL 132MC4BE5/TF/AS7W/Z SIEMENS Motor 1FK7105-5AF71-1EH0 Special motor	.10 .11 .12 .19 .20 .21 .22 .29
Drive arrangement	See pictures above Special design		.XX .99
Divisions Any, maximum 38	Without indexing unit With indexing unit for division XX, symmetrical arrangement Special division		.00 .XX .99
Centre hole	Ø 1,000 mm Extended by 200 mm (not combinable with standard indexing unit) Special design		.0 .1 .9
Measuring system	Measuring system on motor With additional direct measuring system (mounted in standard centre hole) With measuring system in special design		.0 .1 .9
Direction of rotation	Any		
Mounting position	Any, standard table top: horizontal (Please state other mounting positions when ordering)		
Indexing and repeat accuracy No indexing, one drive No indexing, two drives With indexing, one drive With two drives, with measuring system	Indexing accuracy ± 285" ± 60" ± 20" up to ± 5"	Repeat accuracy ± 145" ± 30" ± 10" up to ± 2.5"	

Technical data for FIBROMAT® AT.1600

Maximum axial runout of the table top	0.1 mm	
Maximum runout of the centre hole	0.1 mm	
Weight	FIBROMAT AT.1600 Gear motor Indexing unit	1,400 kg 170 kg 25 kg

Indexing times for FIBROMAT® AT.1600

AT.1600 with one drive										
45°	t _s in s	4.7	4.0	3.3	2.8	2.5	2.3	2.2	2.0	1.7
	J in kgm ²	100,000	75,000	50,000	35,000	25,000	20,000	16,000	12,000	8,000
90°	t _s in s	6.6	5.7	4.7	4.0	3.8	3.4	3.1	2.8	2.5
	J in kgm ²	100,000	75,000	50,000	35,000	25,000	20,000	16,000	12,000	8,000
180°	t _s in s	9.3	8.2	7.0	6.1	5.4	5.0	4.7	4.4	4.1
	J in kgm ²	100,000	75,000	50,000	35,000	25,000	20,000	16,000	12,000	8,000

AT.1600 with two drives										
45°	t _s in s	3.1	2.7	2.2	1.9	1.8	1.6	1.5	1.3	1.2
	J in kgm ²	100,000	75,000	50,000	35,000	25,000	20,000	16,000	12,000	8,000
90°	t _s in s	4.4	3.9	3.4	2.9	2.6	2.4	2.3	2.2	2.0
	J in kgm ²	100,000	75,000	50,000	35,000	25,000	20,000	16,000	12,000	8,000
180°	t _s in s	6.8	6.3	5.7	4.5	4.2	4.0	3.9	3.8	3.7
	J in kgm ²	100,000	75,000	50,000	35,000	25,000	20,000	16,000	12,000	8,000

The specified switching times do not include: Regulation time of 0.1 sec, indexing time of 0.3 sec. Further angles and indexing times can be calculated for you.

Load data for FIBROMAT® AT.1600

Perm. transport load on table top horizontal	25,000 kg
Perm. superstructure diameter	9,500 mm
Perm. force vertically on rotating table top	260,000 N
Perm. radial force on the rotating table top	220,000 N
Perm. tilting moment on rotating table top	135,000 Nm
Perm. tangential moment on table top (dynamic)	16,300 Nm

We would be pleased to provide a calculation of combined load data for your specific application.

Additional options for FIBROMAT® AT.1600

Drive unit Asynchronous motor (standard)		Indexing unit	
Drive unit Synchronous servomotor		Machine stands	
Drive inverter		Additional table top	

CAD data, technical data and planning documentation can be downloaded from www.fibro.com.