

# dankab

VERKTYGSMASKINER AB



# SIC e1-p63c

SÄTTER NY STANDARD FÖR PORTABLA MÄRKMASKINER

# SIC e1-p63c HANDHÅLLEN MÄRKMASKIN

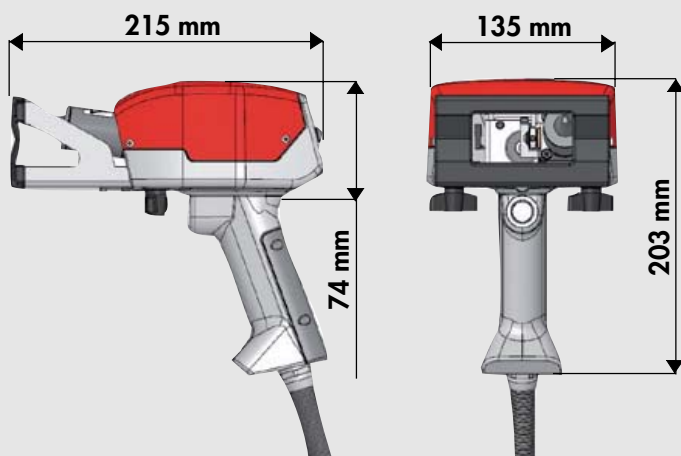

## Märkområde 60 x 25 mm

2,5 tecken/sek

Vikt 2,6 kg

USB

Symboldialog

Färgskärm

Kabel 2,5 m

## Smidig, lätt och välbalanserad

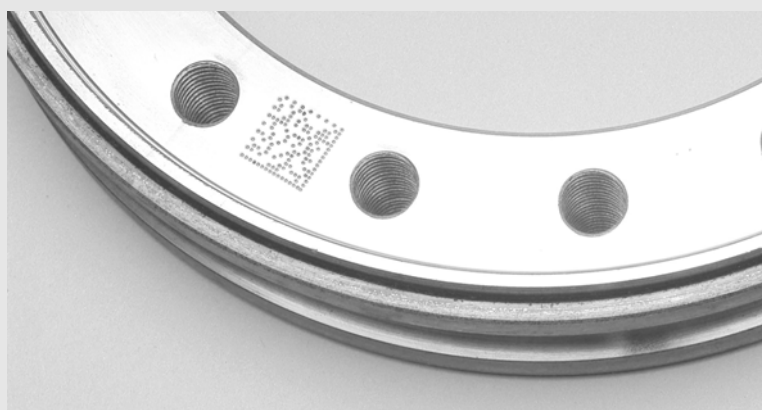

Kan allt – datamatrix, nummerföljder, logotyper etc.



Levereras med väska.



Lätt, bärbar styrning.

## TILLBEHÖR



Stativ.



Anhåll för trånga utrymmen.



Streckkodsläsare.